

HB80-4L

*Multifunctional radio control, rolling code, 433.92 MHz,
4 channels + All, Up-Down-Stop and pulse command*

NEXTA
T E C H



INDEX

1 - PRODUCT FEATURES

1.1 - TECHNICAL DATA

2 - USE OF TRANSMITTER

2.1 - DESCRIPTION OF TRANSMITTER

2.2 - USE OF TRANSMITTER

2.3 - COMMANDS SENT FROM TRANSMITTER

3 - TRANSMITTER PROGRAMMING

3.1 - TRANSMITTER PROGRAMMING

3.2 - "REMOTE" ACTIVATION OF RECEIVER PROGRAMMING

4 - DELETION OF A CHANNEL

4.1 - DELETION OF THE CHANNEL FROM THE RECEIVER

1 - PRODUCT FEATURES

1.1 TECHNICAL DATA

Power supply	Type CR2450 lithium battery
Programmable channels	4
Groups	1, "all" command
Radio frequency	433,92 MHz ISM
Code	Rolling code
Dimensions	Diameter 80 x 13

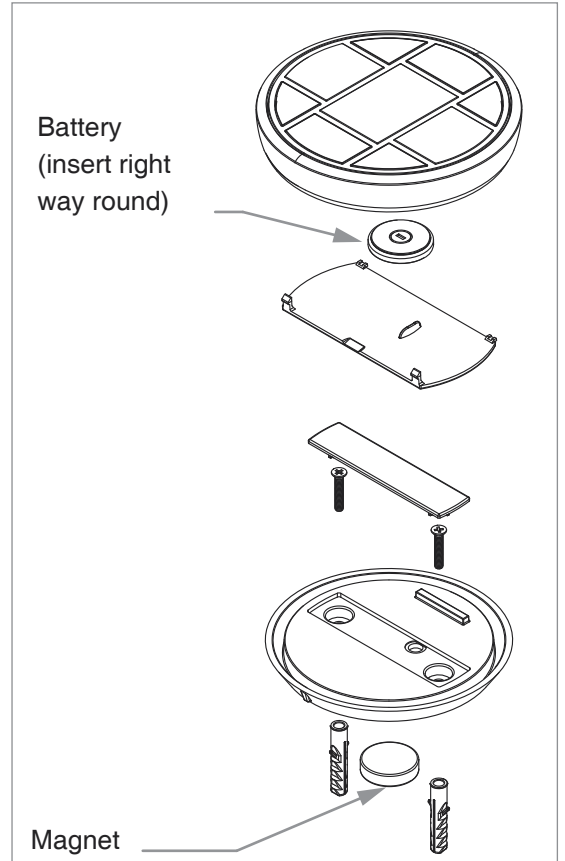
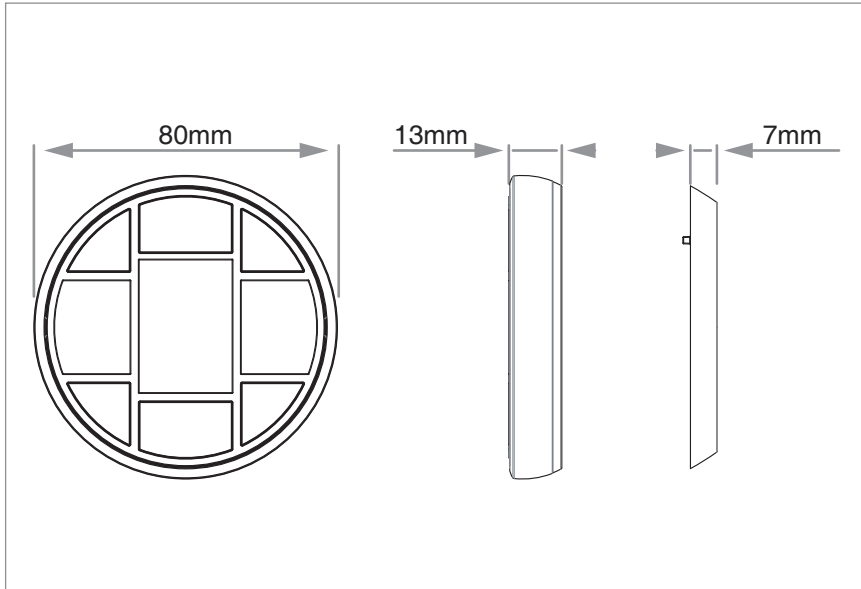

2 - USE OF TRANSMITTER

2.1 DESCRIPTION OF TRANSMITTER

Multichannel radio control to control 4 devices and a group. Up-Down-Stop and pulse controls, LEDs for channel and group selection. Aluminium alloy structure and shock-absorbent polycarbonate plastic parts. Magnetic wall support.

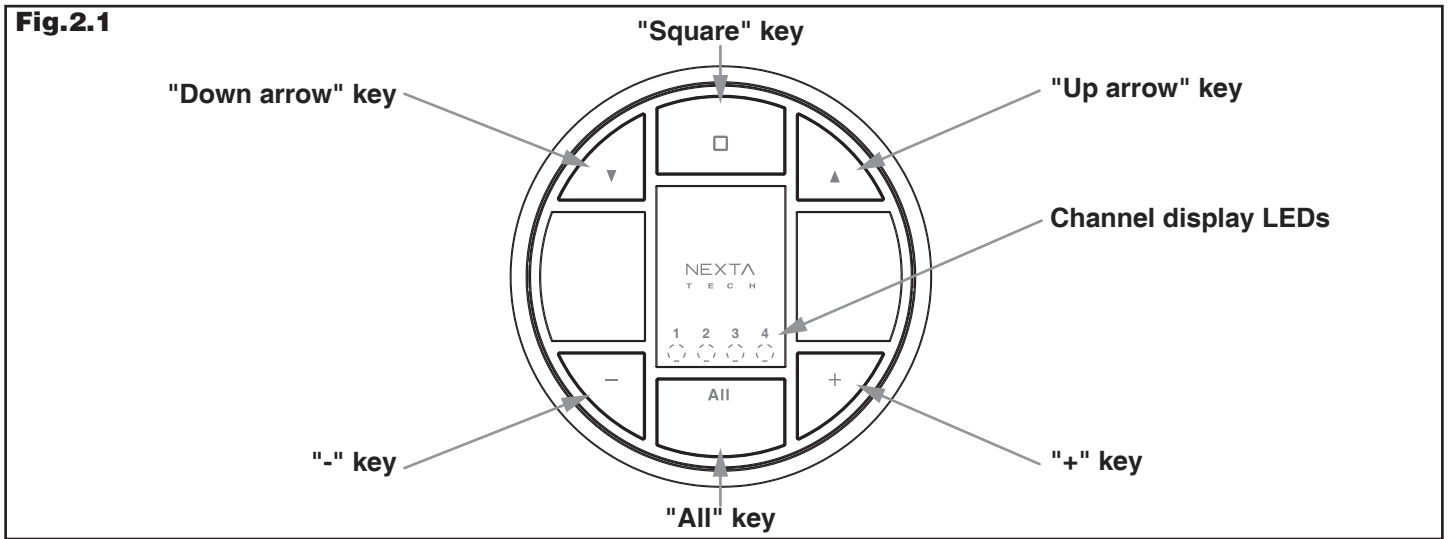

2.2 USE OF TRANSMITTER

To be able to use the transmitter you must first carry out the learning procedures on the receiver (see paragraph 3).

SEND A COMMAND TO A DEVICE:

- 1- With the "+" and "-" keys, select on the LEDs the channel associated with the device that you want to use.
- 2- Send the desired command with the "square", "up arrow" or "down arrow" keys (see paragraph 2.3).
- 3- The transmitter remains in stand-by for 3 seconds and then switches off.

SEND A COMMAND TO A GROUP OF DEVICES:

- 1- Press the "All" key to select all 4 channels (the 4 LEDs switch on).
- 2- Send the desired command with the "square", "up arrow" or "down arrow" keys (see paragraph 2.3).
- 3- The transmitter remains in stand-by for 3 seconds and then switches off.

SWITCHING OFF THE TRANSMITTER

The transmitter automatically switches off after 5 seconds of inactivity; alternatively press the "-" key and the "+" key at the same time.

2.3 COMMANDS SENT FROM TRANSMITTER

The following table shows the different commands the transmitter sends depending on the device it is programmed on. The left-hand column shows the transmitter commands, the top row the type of controller

Transmitter key	Monostable device	Timed device	On/off device	Dimmer device	RGBW device	CCT device	Up/down/stop device	Connector device
□ Short	Pulse	Timer starts	On/Off	On/Off	On/Off	On/Off	Stop	On/Off
□ Long (>3s)	-	Off	Off	Off	Off	Off	-	-
▲	-	Timer starts	On	LIGHT OFF: On 60% LIGHT ON: Dimmer UP	Dimmer Up	Dimmer Up	Open	-
▼	-	Off	Off	LIGHT OFF: On 30% LIGHT ON: Dimmer down	Dimmer Down	Dimmer Down	Close	-

3 - TRANSMITTER PROGRAMMING

To use the transmitter at least one channel must be programmed (paragraph 3.1).

3.1 TRANSMITTER PROGRAMMING

Default: no channel programmed

This procedure is used to programme a channel in order to then associate it with a compatible receiver. Access to the receiver is required to carry out the following procedure.

PROCEDURE:

- 1- Activate the receiver on which you want to programme the transmitter in "multifunctional remote control radio programming" mode (see receiver manual)
- 2- With the transmitter in stand-by (transmitter off), use the "+" and "-" keys to select the channel that you want to associate with the receiver and use the "square" key to send a transmission.
- 3- The receiver flashes 3 times to confirm the learning procedure (see receiver manual).
- 4- The transmitter goes back into stand-by.

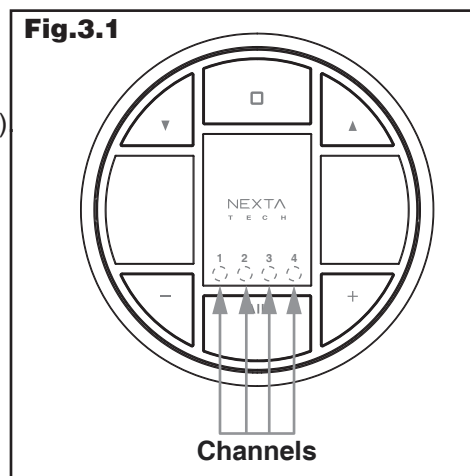

3.2 "REMOTE" ACTIVATION OF RECEIVER PROGRAMMING

Once the transmitter has been programmed following the procedure in paragraph 3.1, this transmitter can be used for remote activation of receiver programming and therefore to add further remote controls without accessing the receiver.

PROCEDURE:

- 1- Take up position near to the receiver.
- 2- With the transmitter already programmed, choose the channel associated with the receiver and press the "up arrow" and "down arrow" keys at the same time for 3 seconds (the transmitter will start to flash). The receiver that the transmitter channel has been programmed on is activated for 30 seconds
- 3- Send a command with the new transmitter that you want to programme (see transmitter manual for use).

WARNING: Once the signal has been received from the new transmitter, the control unit will go back to normal operation; if you want to programme other transmitters repeat the procedure.

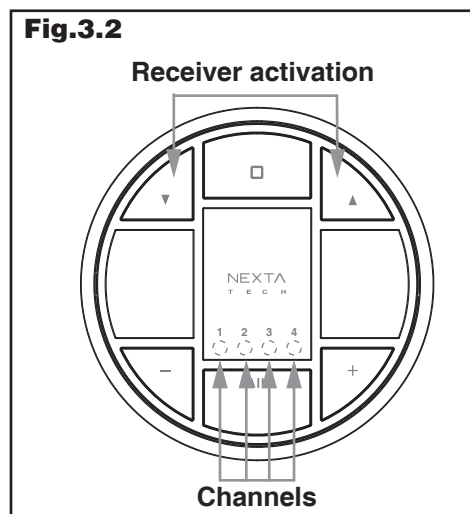

4 - DELETION OF A CHANNEL CEIVER

4.1 DELETION OF THE CHANNEL FROM THE RECEIVER

This procedure is to delete one of the transmitter's channels from the memory of the receiver on which it was programmed.

PROCEDURE:

- 1- Access the receiver and carry out the "delete single transmitter" procedure (see receiver manual).



MNLB80-4LENV1.0

Nexta Tech

company brand of Team srl
via G.Oberdan 90, 33074
Fontanafredda (PN) - Italy
Ph. +39 0434 998682
Email: info@nexta-tech.com
Web: www.nexta-tech.com